

# LOW HEADROOM CHAIN HOISTS

## DATA SHEET

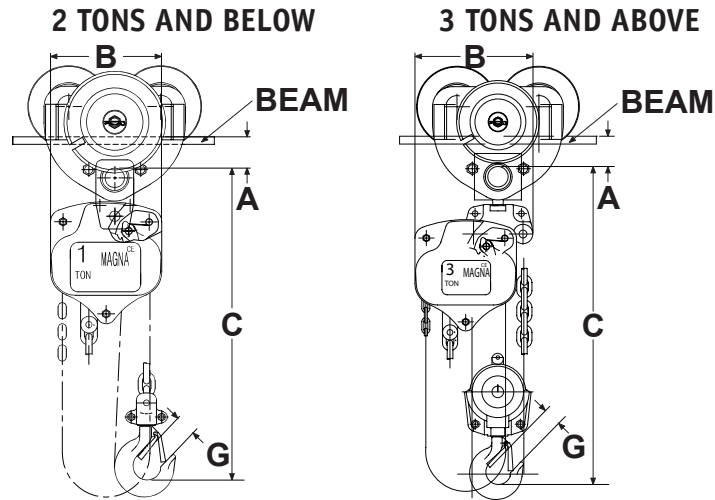

**NOTE:** DIMENSIONS SHOWN ARE BASED ON USE WITH A MAGNA SUPPLIED TROLLEY.

MODEL NUMBERS	CH050LM	CH100LM	CH150LM	CH200LM	CH300LM	CH500LM	CH750LM	CH1000LM
<b>CAPACITY (POUNDS)</b>	1,100	2,200	3,300	4,400	6,600	11,000	16,500	22,000
<b>STANDARD LIFT (FEET)</b>	10	10	10	10	10	10	10	10
<b>LOAD CHAIN (MILLIMETERS)</b>	6.3 x 19.1	6.3 x 19.1	7.1 x 21.0	7.9 x 23.0	7.1 x 21.0	9.0 x 27.0	9.0 x 27.0	9.0 x 27.0
<b>LOAD CHAIN GRADE</b>	Grade 80	Grade 80	Grade 80	Grade 80	Grade 80	Grade 100	Grade 100	Grade 100
<b>HAND CHAIN* (MILLIMETERS)</b>	0.5 x 22.5	0.5 x 22.5	0.5 x 22.5	0.5 x 23.4	0.5 x 22.5	0.5 x 23.4	0.5 x 23.4	0.5 x 23.4
<b>PULL TO LIFT LOAD (POUNDS)</b>	53	73	75	75	77	86	90	90
<b>NET WEIGHT WITH STANDARD LIFT (POUNDS)</b>	24.3	25.4	30.4	47.6	50.7	90.4	125.7	171.1
<b>LOAD CHAIN FALL (LINES)</b>	1	1	1	1	2	2	3	4
<b>WEIGHT FOR ADDITIONAL FIVE FEET OF LIFT (POUNDS)</b>	6.1	6.1	6.9	7.9	10.6	15.4	21.4	27.4
<b>TEST LOAD (POUNDS)</b>	1,653	3,307	4,960	6,614	9,921	16,535	24,802	33,069
<b>DIMENSIONS (INCHES)</b>								
<b>A</b>	1.6	1.5	1.9**	1.9	2.3	2.9	2.9	2.9
<b>B</b>	6.1	6.1	6.9	8.0	8.1	10.4	14.2	14.5
<b>C</b>	11.0	11.0	12.0	13.4	17.3	23.6	27.6	29.9
<b>G</b>	1.1	1.2	1.3	1.5	1.7	1.8	1.8	2.4

\*HAND CHAIN DROP LENGTH IS EQUAL TO THE LOAD CHAIN LENGTH UNLESS OTHERWISE REQUESTED

\*\*USING A 2 TON CAPACITY TROLLEY